

Technical sheet :

EP 20



Technical characteristics			Metric
1.1	Manufacturer		Manitou
1.2	Model Name		EP 20
1.3	Power source		Battery
1.4	Operator type		Pedestrian
1.5	Max. capacity	Q	2000 kg
1.6	Load centre of gravity	c	600 mm
1.8	Load distance, centre of drive axle to fork	x	953 mm
1.9	Wheelbase	y	1372 mm
Weight			
2.1	Service weight		482 kg
2.2	Weight on front axle (laden) / rear axle (laden)		1077 kg / 1405 kg
2.3	Weight on front axle (Unladen) / rear axle (Unladen)		337 kg / 145 kg
Wheels			
3.1	Tyres type		Bandage
3.2	Dimensions of front wheels		230 x 75
3.3	Dimensions of rear wheels		4 x (82 x 70)
3.4	Additional wheels (dimensions)		2 x (100 x 40)
3.5	Number of front wheels / rear wheels		3 / 4
3.6	Front wheel gauge	b10	435 mm
3.7	Rear wheel gauge	b11	366 mm
Dimensions			
4.4	Max. lifting height	h3	125 mm
4.9	Height tiller up min.	h14	866 mm
4.9	Height tiller up max.	h14	1320 mm
4.15	Fork height in low position	h13	85 mm
4.19	Overall length	l1	1739 mm
4.20	Length to face of forks	l2	589 mm
4.21	Overall width	b1	680 mm
4.22	Forks section / width / length	s / e / l	45 mm x 175 mm / 1150 mm
4.25	Fork spread	b5	540 mm
4.32	Ground clearance at centre of wheelbase	m2	35 mm
4.34	Aisle width for 800 x 1200 pallet lengthways	Ast	1939 m
4.35	Turning radius	Wa	1544 mm
Performances			
5.1	Travel speed (laden / unladen)		5.80 km/h / 6 km/h
5.2	Lifting speed (laden / unladen)		0.02 m/s / 0.03 m/s
5.3	Lowering speed (laden / unladen)		0.04 m/s / 0.02 m/s
5.7	Gradeability (laden / unladen)		10 % / 25 %
5.10	Service brake		Electro magnetic
5.11	Parking brake		Handle Release
Engine			
6.1	Drive motor rating S2 60 min		1.20 kW
6.2	Lift motor rating at S3 15%		1 kW
6.3	Battery according to DIN 43531/35/36 A, B, C		DIN 43535-B
6.4	Battery / Batteries capacity		24 V / 180 Ah
6.5	Battery weight (+/- 5%)		180 kg
Miscellaneous			
8.1	Type of drive control		AC
8.4	Measured/guaranteed mean noise level at the ear of the operator		< 65 dB(A)

EP 20 - Dimensional drawing

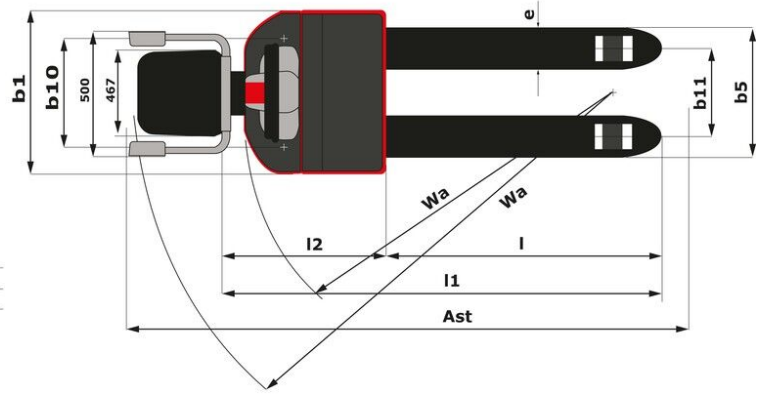
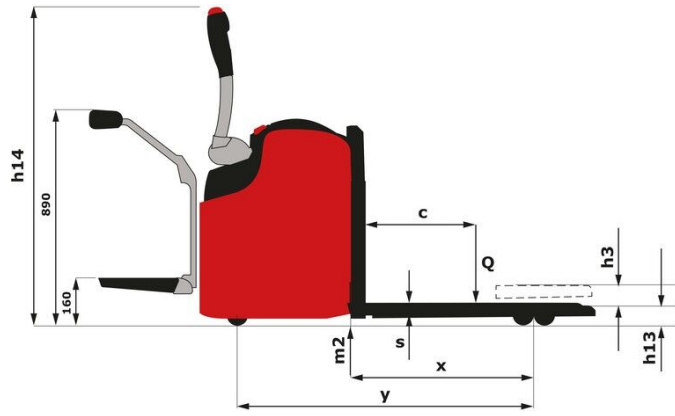



Siège Social

430 rue de l'Aubinière - 44150 Ancenis Cedex - France

Tel: +33(0)2 40 09 10 11 - Fax: +33 (0)2 40 09 10 97

www.manitou.com



This brochure describes versions and configuration options for Manitou products which may be fitted with different equipment. The equipment described in this brochure may be standard, optional or not available depending on version. Manitou reserves the right to change the specifications shown and described at any time and without prior warning. The manufacturer is not liable for the specifications given. For more information, contact your Manitou dealer. Non-contractual document. Product descriptions may differ from actual products. List of specifications is not comprehensive. The logos and visual identity of the company are the property of Manitou and may not be used without authorisation. All rights reserved. The photos and diagrams contained in this brochure are provided for information only.

MANITOU BF SA - Limited company with board of directors - Share capital: 39,668,399 euros - 857 802 508 RCS Nantes