

Technical sheet :

MSI 30 ST5



	Technical characteristics		Metric
1.1	Manufacturer		Manitou
1.2	Model Name		MSI 30 ST5
1.3	Power source		Diesel
1.4	Operator type		Seated
1.5	Max. capacity	Q	3000 kg
1.6	Load centre of gravity	c	500 mm
1.8	Load distance, centre of drive axle to fork	x	626 mm
1.9	Wheelbase	y	1900 mm
	Weight		
2.1	Service weight		4400 kg
2.2	Weight on front axle (laden) / rear axle (laden)		6560 kg / 840 kg
2.3	Weight on front axle (Unladen) / rear axle (Unladen)		1660 kg / 2740 kg
	Wheels		
3.1	Tyres type		Pneumatic
3.2	Dimensions of front wheels		300-15/18 6T P43
3.3	Dimensions of rear wheels		7.00-12/12 ED PLUS
3.5	Number of front wheels / rear wheels		2 / 2
3.5.2	Number of drive wheels		2
3.6	Front wheel gauge	b10	1044 mm
3.7	Rear wheel gauge	b11	1108 mm
	Dimensions		
4.1	Tilt of Mast Forward (deg) / Backward (deg)	α / β	12 / 10
4.7	Height of overhead guard (cabin)	h6	2095 mm
4.8	Seat height/stand height	h7	972 mm
4.19	Overall length	l1	4234 mm
4.20	Length to face of forks	l2	3034 mm
4.21	Overall width	b1	1330 mm
4.22	Forks section / width / length	s / e / l	45 mm x 100 mm / 1200 mm
4.23	Fork carriage ISO 2328 (class/form) A/B		FEM 3A
4.24	Fork carriage width	b3	1260 mm
4.31	Ground clearance below mast	m1	260 mm
4.32	Ground clearance at centre of wheelbase	m2	238 mm
4.33	Aisle Width for pallets 1000 x 1200 crossways	Ast	4676 mm
4.35	Turning radius	Wa	2650 mm
	Performances		
5.1	Travel speed (laden / unladen)		21 km/h / 21 km/h
5.2	Lifting speed (laden / unladen)		0.50 m/s / 0.50 m/s
5.3	Lowering speed (laden / unladen)		0.50 m/s / 0.30 m/s
5.5	Drawbar pull (Laden)		1900 daN
5.7	Gradeability (laden)		27 %
5.10	Service brake		Hydraulic brakes by loss of pressure
	Engine		
7.1	Engine brand / model		Kubota / D1803 CRT E5B
7.2	Engine power according to ISO 1585		37 kW
7.3	Rated speed		2700 rpm
7.4	Number of cylinders / Capacity of cylinders		3 - 1826 cm ³
7.5	Fuel consumption according to VDI cycle		3.70 l/h
	Miscellaneous		
8.1	Type of drive control		Electronic
8.2	Working hydraulic pressure for attachments		220 bar
8.3	Oil flow rate for attachments		25 l/min

MSI 30 ST5 - Dimensional drawing

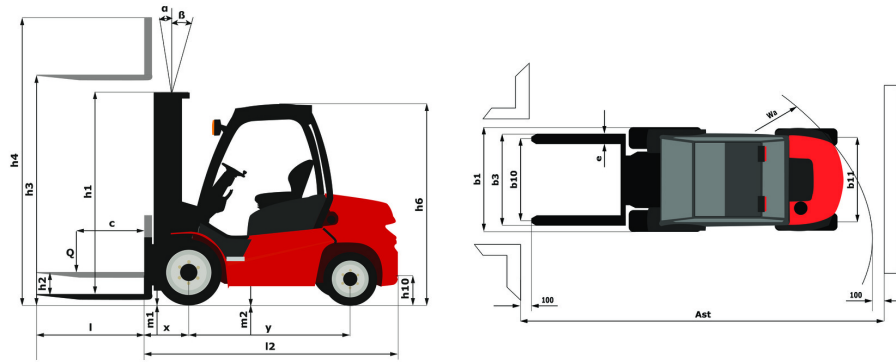

Characteristics of masts and residual capacities

Full Visibility Duplex		FVD 30	FVD 33	FVD 37	FVD 40	FVD 45
h2 - Free lift	mm	90	90	90	90	90
h1 - Height mast lowered *	mm	2136	2286	2546	2736	2986
h3 - Lifting Height	mm	3000	3300	3700	4000	4500
h4 - Height mast extended *	mm	3738	4038	4438	4738	5238
α / β - Mast inclination (front / rear)	°	12 / 10	12 / 10	12 / 10	12 / 10	12 / 10
Residual capacity at max height	kg	3000	3000	3000	3000	3000
Residual capacity with hooked-on side shift (Industrial load chart)	kg	3000	3000	3000	3000	
Height at max capacity	mm	3000	3300	3700	4000	4500
Height at max capacity with hooked-on sideshift	mm	3000	3300	3700	4000	

Free Lift Triplex		FLT 34	FLT 37	FLT 40	FLT 43	FLT 47	FLT 55	FLT 60
h2 - Free lift	mm	1208	1308	1408	1558	1658	2008	2258
h1 - Height mast lowered *	mm	1936	2036	2136	2286	2386	2736	2986
h3 - Lifting Height	mm	3400	3700	4000	4300	4700	5500	6000
h4 - Height mast extended *	mm	4184	4484	4784	5084	5484	6284	6784
α / β - Mast inclination (front / rear)	°	12 / 10	12 / 10	12 / 10	12 / 10	12 / 10	6 / 6	6 / 6
Residual capacity at max height	kg	3000	3000	3000	3000	2700	2300	2200
Residual capacity with hooked-on side shift (Industrial load chart)	kg	3000	3000	3000	3000	2700		2200
Height at max capacity	mm	3400	3700	4000	4300	4300	4200	4200
Height at max capacity with hooked-on sideshift	mm	3400	3700	4000	4300	4200		4200

Full Visibility Triplex		FVT 33
h2 - Free lift	mm	77
h1 - Height mast lowered *	mm	1826
h3 - Lifting Height	mm	3300
h4 - Height mast extended *	mm	4027
α / β - Mast inclination (front / rear)	°	12 / 10



Siège Social

430 rue de l'Aubinière - 44150 Ancenis Cedex - France

Tel: +33(0)2 40 09 10 11 - Fax: +33 (0)2 40 09 10 97

www.manitou.com



This brochure describes versions and configuration options for Manitou products which may be fitted with different equipment. The equipment described in this brochure may be standard, optional or not available depending on version. Manitou reserves the right to change the specifications shown and described at any time and without prior warning. The manufacturer is not liable for the specifications given. For more information, contact your Manitou dealer. Non-contractual document. Product descriptions may differ from actual products. List of specifications is not comprehensive. The logos and visual identity of the company are the property of Manitou and may not be used without authorisation. All rights reserved. The photos and diagrams contained in this brochure are provided for information only.

MANITOU BF SA - Limited company with board of directors - Share capital: 39,668,399 euros - 857 802 508 RCS Nantes