

Technical sheet :

M 50-4 ST5



	Technical characteristics		Metric
1.1	Manufacturer		MANITOU
1.2	Model Name		M 50-4 ST5
1.3	Power source		Diesel
1.4	Operator type		Seated
1.5	Max. capacity	Q	5000 kg
1.6	Load centre of gravity	c	600 mm
1.8	Load distance, centre of drive axle to fork	x	773 mm
1.9	Wheelbase	y	2120 mm
	Weight		
2.1	Service weight		8325 kg
2.2	Weight on front axle (laden) / rear axle (laden)		11520 kg / 1805 kg
2.3	Weight on front axle (Unladen) / rear axle (Unladen)		3285 kg / 5040 kg
	Wheels		
3.1	Tyres type		Pneumatic
3.2	Dimensions of front wheels		18-22,5 MPT-06
3.3	Dimensions of rear wheels		340/80 R18 XMCL
3.5	Number of front wheels / rear wheels		2 / 2
3.5.2	Number of drive wheels		4
3.6	Front wheel gauge	b10	1620 mm
3.7	Rear wheel gauge	b11	1740 mm
	Dimensions		
4.1	Tilt of Mast Forward (deg) / Backward (deg)	α / β	15 / 15
4.7	Height of overhead guard (cabin) / Overall height of low overhead guard (Buggie version)	h6 / h6*	2486 mm / 2486 mm
4.8	Seat height/stand height	h7	1455 mm
4.19	Overall length	l1	4948 mm
4.20	Length to face of forks	l2	3748 mm
4.21	Overall width	b1	2080 mm
4.22	Forks section x width x length	s / e / l	60 mm x 150 mm / 1200 mm
4.23	Fork carriage ISO 2328 (class/form) A/B		FEM 4A
4.24	Fork carriage width	b3	1670 mm
4.31	Ground clearance below mast	m1	300 mm
4.32	Ground clearance at centre of wheelbase	m2	426 mm
4.33	Aisle width for 1000 x 1200 pallet widthways	Ast	6812 mm
4.34	Aisle width for 800 x 1200 pallet lengthways	Ast	6812 mm
4.35	Turning radius	Wa	4640 mm
	Performances		
5.1	Travel speed (laden / unladen)		10 km/h / 22 km/h
5.2	Lifting speed (laden / unladen)		0.40 m/s / 0.40 m/s
5.3	Lowering speed (laden / unladen)		0.50 m/s / 0.40 m/s
5.5	Drawbar pull (Laden)		11000 daN
5.10	Service brake		Hydraulic
	Engine		
7.1	Engine brand / model		Deutz / TCD 2,9
7.2	Engine power according to ISO 1585		55 kW
7.3	Rated speed		2300 rpm
7.4	Number of cylinders / Capacity of cylinders		4 - 2925 cm ³
7.5	Fuel consumption according to VDI cycle		8 l/h
	Miscellaneous		
8.1	Type of drive control		Electric
8.2	Working hydraulic pressure for attachments		230 bar
8.3	Oil flow rate for attachments		97 l/min
8.4	Sound level at the driver's ear according to DIN 12 053		78 dB(A)

Dimensional drawing

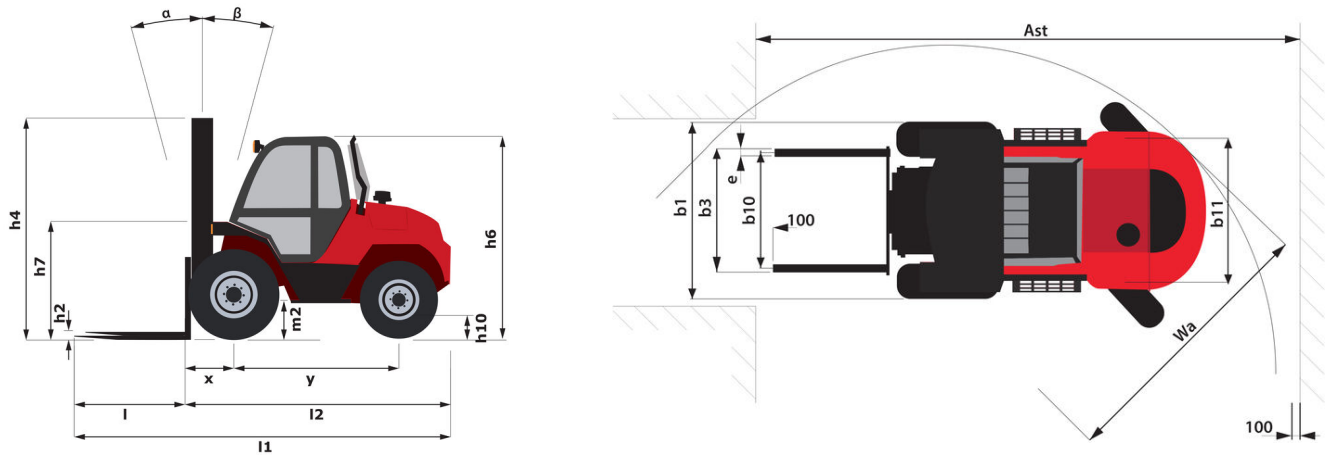

Characteristics of masts and residual capacities

Full Visibility Duplex		FVD 30	FVD 33	FVD 35	FVD 37	FVD 40	FVD 45	FVD 50
h1 - Height mast lowered *	mm	2520	2670	2770	2870	3020	3270	3520
h4 - Height mast extended *	mm	4070	4370	4570	4770	5070	5570	6070
h3 - Max. lifting height	mm	3000	3300	3500	3700	4000	4500	5000
α / β - Mast inclination (front / rear)	°	15 / 15	15 / 15	15 / 15	15 / 15	15 / 15	15 / 15	15 / 15
Residual capacity at max height	kg	5000	5000	5000	5000	5000		2200
Residual capacity without attachment (Off road load chart)	kg	5000	5000	5000	5000	5000		2200
Residual capacity with hooked-on side shift (Off road load chart)	kg	4700	4700	4700	4700	4700	4000	
Height at max capacity	mm	3000	3300	3500	3700	4000		4000
Height at max capacity with hooked-on sideshift	mm	3000	3300	3500	3700	4000	4000	

Free Lift Triplex		FLT 37	FLT 40	FLT 43	FLT 45	FLT 47	FLT 50	FLT 55	FLT 60
h2 - Free lift	mm	1255	1355	1455	1530	1590	1705	1855	2030
h1 - Height mast lowered *	mm	2270	2370	2470	2545	2605	2720	2870	3045
h4 - Height mast extended *	mm	4770	5070	5370	5570	5770	6070	6570	7070
h3 - Max. lifting height	mm	3700	4000	4300	4500	4700	5000	5500	6000
α / β - Mast inclination (front / rear)	°	15 / 15	15 / 15	15 / 15	15 / 15	15 / 15	10 / 15	10 / 15	10 / 15
Residual capacity at max height	kg			4500	4350	3500	2800	1800	900
Residual capacity without attachment (Off road load chart)	kg			4500	4350	3500	2800	1800	900
Residual capacity with hooked-on side shift (Off road load chart)	kg		4500		4100	3600	2100	2000	900
Height at max capacity	mm			3800	4000	4000	4000	4000	
Height at max capacity with hooked-on sideshift	mm		3000						



Siège Social

430 rue de l'Aubinière - 44150 Ancenis Cedex - France

Tel: +33(0)2 40 09 10 11 - Fax: +33 (0)2 40 09 10 97

www.manitou.com



This brochure describes versions and configuration options for Manitou products which may be fitted with different equipment. The equipment described in this brochure may be standard, optional or not available depending on version. Manitou reserves the right to change the specifications shown and described at any time and without prior warning. The manufacturer is not liable for the specifications given. For more information, contact your Manitou dealer. Non-contractual document. Product descriptions may differ from actual products. List of specifications is not comprehensive. The logos and visual identity of the company are the property of Manitou and may not be used without authorisation. All rights reserved. The photos and diagrams contained in this brochure are provided for information only.

MANITOU BF SA - Limited company with board of directors - Share capital: 39,668,399 euros - 857 802 508 RCS Nantes